

WE ARE GLASS PEOPLE

HEYE

LEHR LOADER

Type 4201



h heye
international

THE HEYE LEHR LOADER

The Lehr Loader Type 4201 has been designed for the application at hollow glass production machines with a speed of up to 14 cycles/minute. It pushes the articles by means of a push bar from the cross conveyor to the lehr belt.

Function

The push bar is fixed at the Lehr Loader portal that is supported movably by bearings on a swivel frame. On the swivel frame a pneumatic cylinder is connected at the Lehr Loader portal. By moving the Lehr Loader portal the lifting movement of the push bar is generated.

The entire assembly consisting of push bar, Lehr Loader portal and swivel frame carries out the loading movement guided by arms. This movement is generated by a servo motor. It is converted by a toothed belt drive, a worm gearing and a crank drive.

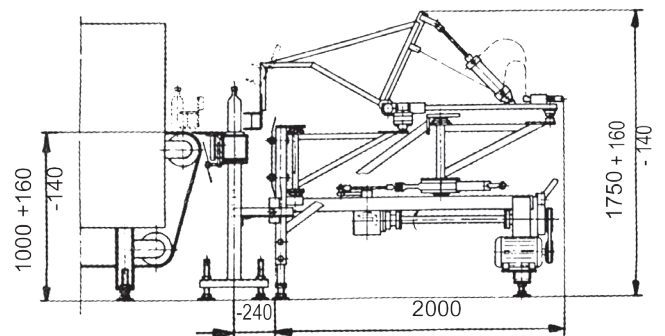

Loading procedure

The loading begins when the push bar engages the bottle stream by a movement in direction of the cross conveyor and continuously changes on an arc in direction of the lehr belt.

The overlap of the movement in cross and longitudinal direction is designed in such a way that the relative speed between bottle and cross conveyor is very low when contacting the articles.

During loading the continuousness of the bottle stream on the cross conveyor is not impeded by the offset of the Lehr Loader portal.

At the end of the loading procedure Lehr Loader push bar and Lehr Loader portal are lifted by a pneumatic cylinder to be moved backwards over the bottle stream of the cross conveyor in order to be lowered again in front of the bottles stream for a new loading cycle.

To protect the Lehr Loader an overload clutch is installed between driving arm and drive rocker. It unlocks when the loading movement is blocked.

Lubrication

All bearings as well as contacting roller surfaces are supplied with grease via a central lubrication unit. The lubrication is effected periodically via the control system. The lubrication process and the filling level of the storage tank are monitored.

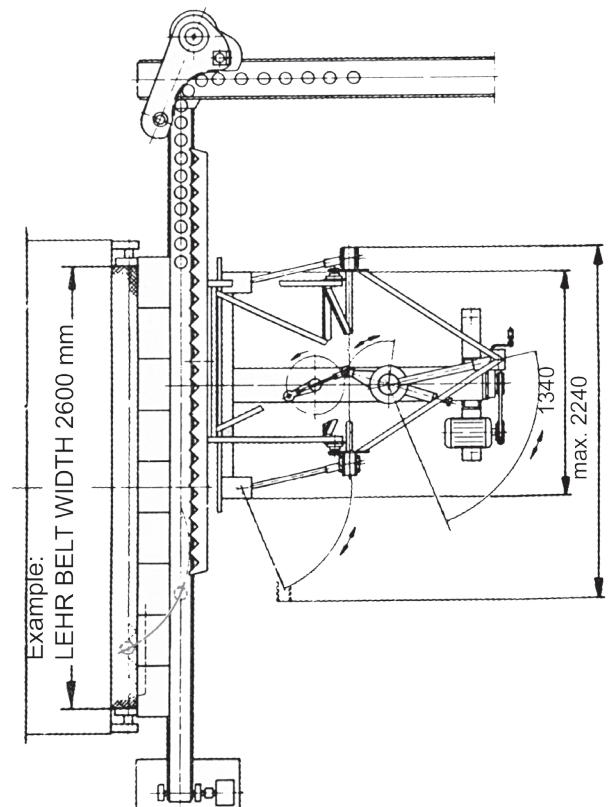

CONTROL UNIT

To control the servo motor the Heye Simotion® Servodrive is used. Also please see product description

“Heye Simotion® Servodrive”.

Heye Simotion® Servodrive

This highly-flexible control is based on the future-proof multi axis drive System Simotion® of Siemens. Excellent reliability of the electronic components in combination with the application of a compact servo motor with robust resolver guarantee a reliable non-stop operation. Even with respect to servicing this control is perfect as it is easy to handle. If control components should have to be exchanged complicated manual addressing or programming is not necessary because the configuration data are stored on a memory board. When the control is started the data are automatically transferred. Hence, the commissioning times and downtimes in case of servicing are short, the training effort for the service staff is less. Fault and operating messages that appeared are registered by the control unit with date and time and can be read in detail on the touchscreen anytime.

The Lehr Loader is driven by a continuously operating servo motor.

Before starting the Lehr Loader the number of rows has to be entered via the touchscreen. By means of local control elements the Lehr Loader is switched on and off and the position of the push bar is set in correct phase relation to the arriving articles.

The control can be upgraded: in addition to the Lehr Loader almost all drives of the following Heye equipment can be combined in one control unit as desired: Stirrer, Plunger, Gob Distributor, Machine Conveyor, Ware Transfer, Cross Conveyor and Lehr.

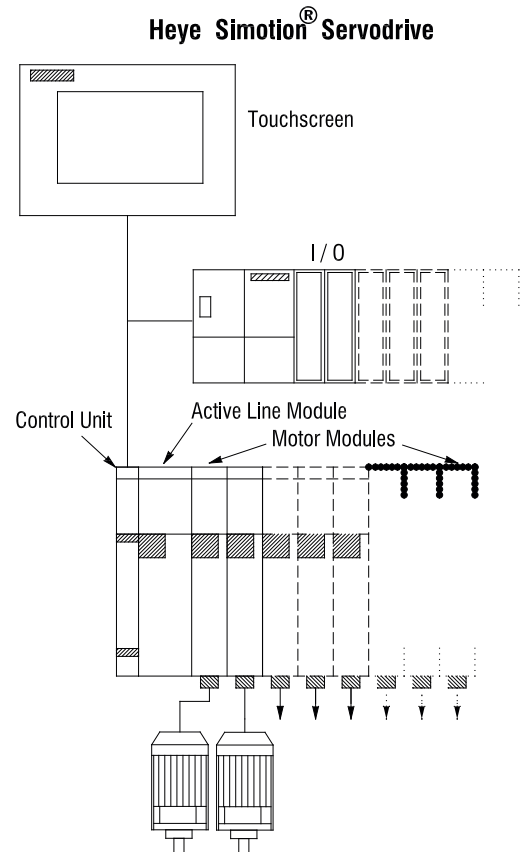

Range of application of diverse Heye Lehr Loaders

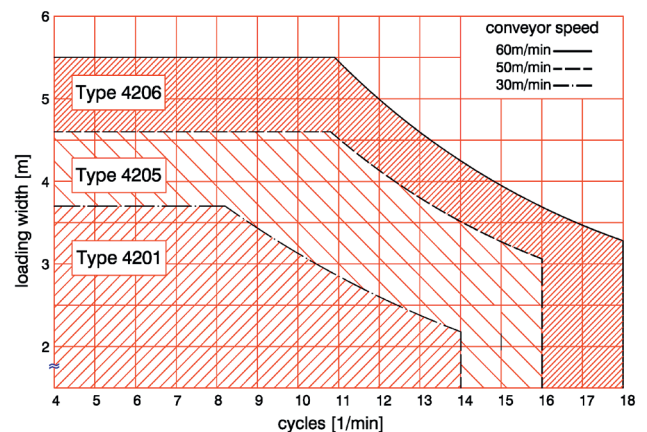

Type 4206:
intermittent drive with three servo motors

Type 4205:
intermittent drive with two servo motors

Type 4201:
continuous drive

OVERVIEW

Advantages

- Simple operation
- Simple design

Scope of Delivery

- Lehr Loader
- Protections
- Control box
- Control Heye Simotion® Servodrive
Type 4520 with touchscreen
- Cable set

Emissions

- The A-weighted permanent sound pressure level of this system is below 70 dB(A)

Technical Data

- Speed up to 14 cycles/minute
- Max. number of articles approx. 400/minute
- Max. article height 350 mm
- Stroke in lehr direction 269 mm - 386 mm
- Length (in lehr direction, in starting position) approx. 2000 mm
- Width approx. 1340 mm
- Height at a lehr belt height of 1000 mm approx. 1740 mm
- Height adjustable + 160 mm, - 140 mm
- Weight with motor approx. 420 kg
- Compressed air, primary pressure min. 4 bar, max. 11 bar
- Operating pressure 2.5 - 3.5 bar
- Consumption 6 m³

Control

- Dimensions width/height/depth 800 / 2200 / 600 mm
1000 / 2200 / 600 mm
1200 / 2200 / 600 mm
- Weight 320 - 400 kg
- Power input with two active ventilators depending on the number of axes
- Cables to the control cabinet 4 x 6 mm²
- Mains supply three-phase 400 - 480 V ± 10%
PE, no neutral wire
- Mains frequency 50/60 Hz ± 6%
- Mains fuse 35 A slow-blow (to be made available by the user)
- Ambient temperature for the control unit max. 35°C